

**Repar2** | 50 Years  
MACHINE GUARDS 

Via Ambrogio Colombo, 176 - 21055 Gorla Minore (VA) Italy  
Tel. +39 0331 465727 Fax: +39 0331 465728  
www.repar2.com info@repar2.com  
Exp.Dept: exportoffice@repar2.com

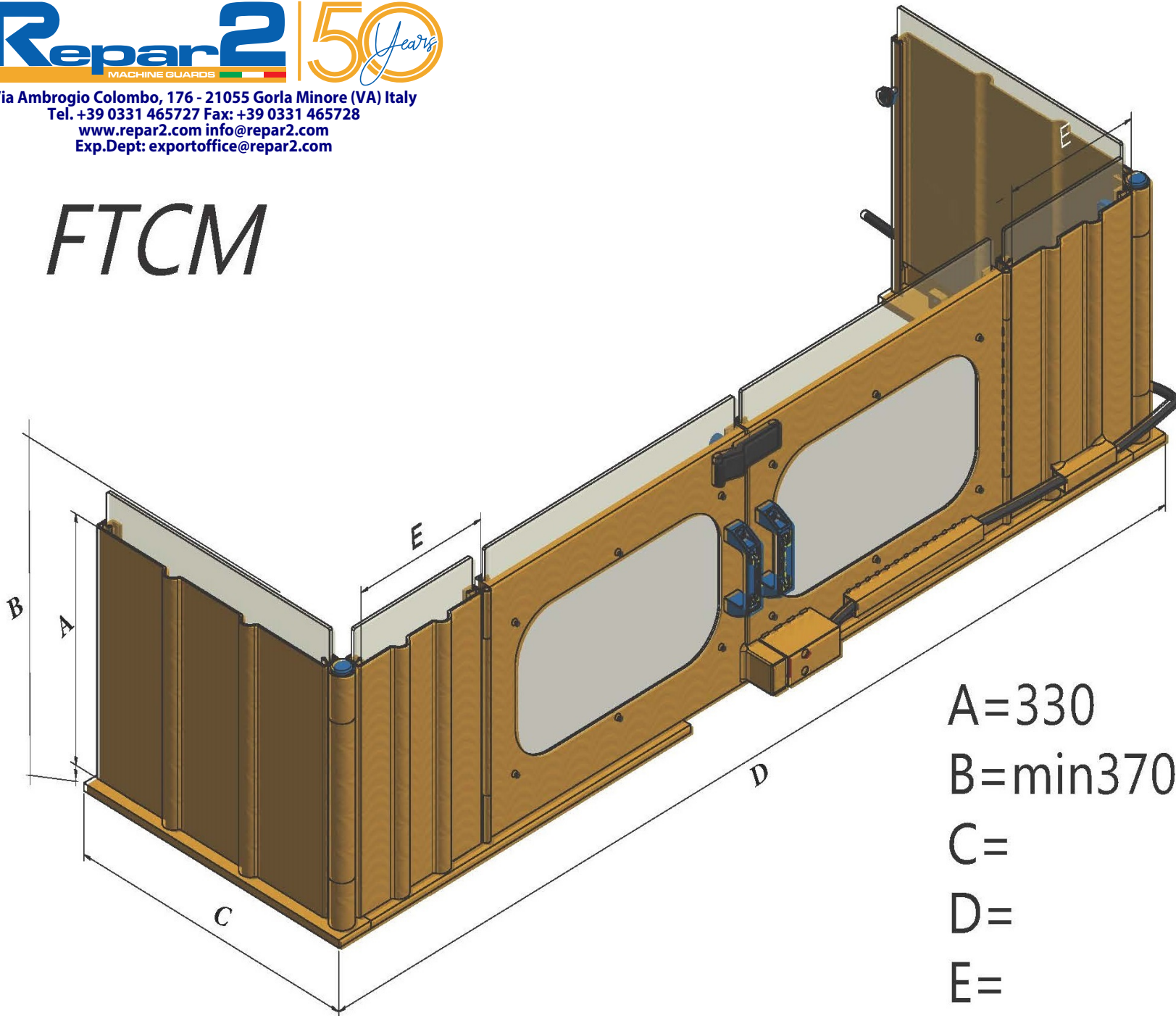

# FTCM



A=330

B=min370 max630

C=

D=

E=

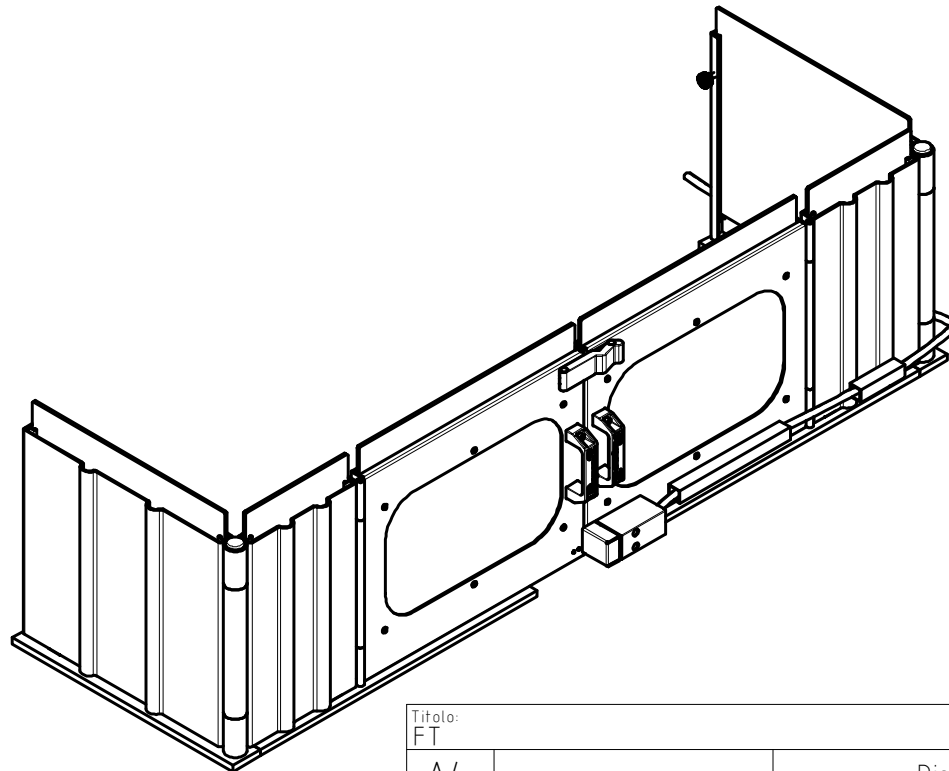
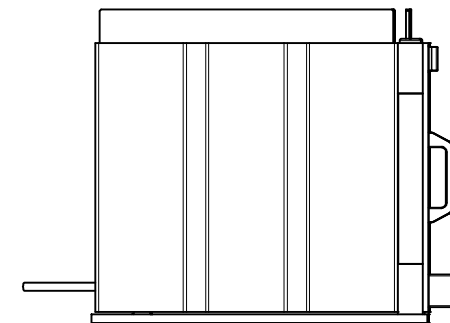
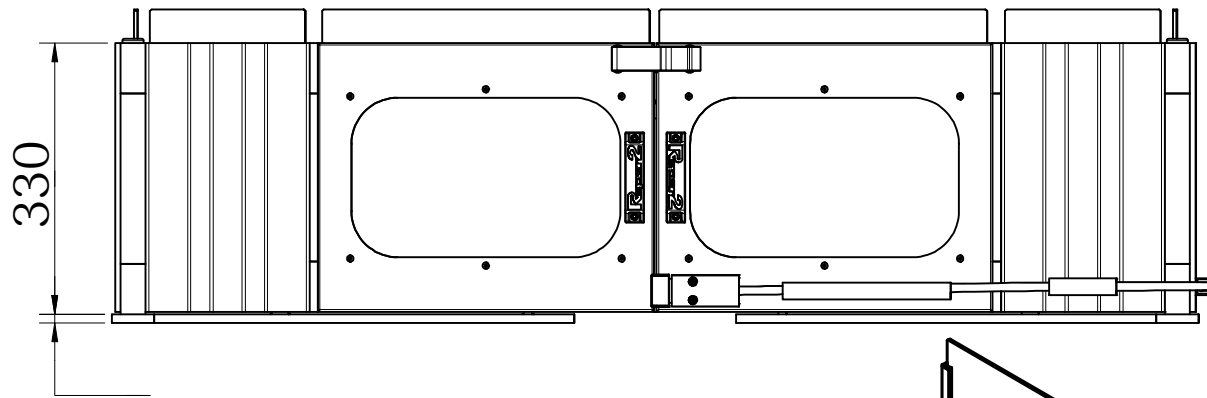

Via Ambrogio Colombo, 176 - 21055 Gorla Minore (VA) Italy  
 Tel. +39 0331 465727 Fax: +39 0331 465728  
 www.repar2.com info@repar2.com  
 Exp.Dept: exportoffice@repar2.com

Titolo: FT		Data: 08/11/2019		Scala principale: 1 : 9		Progettista: Alejandro Martin Alva Fuentes	
A4		Dis.		Disegnato da: Alejandro Martin Alva Fuentes			
Progetto:			Colore:		Massa: 27,343 kg		Verificato da: Marco Ottavio Carnovali
Tolleranze dimensionali generali: UNI EN 22768-mK.			Codice articolo: Protezione FT			Numero disegno:	
		Descrizione:					

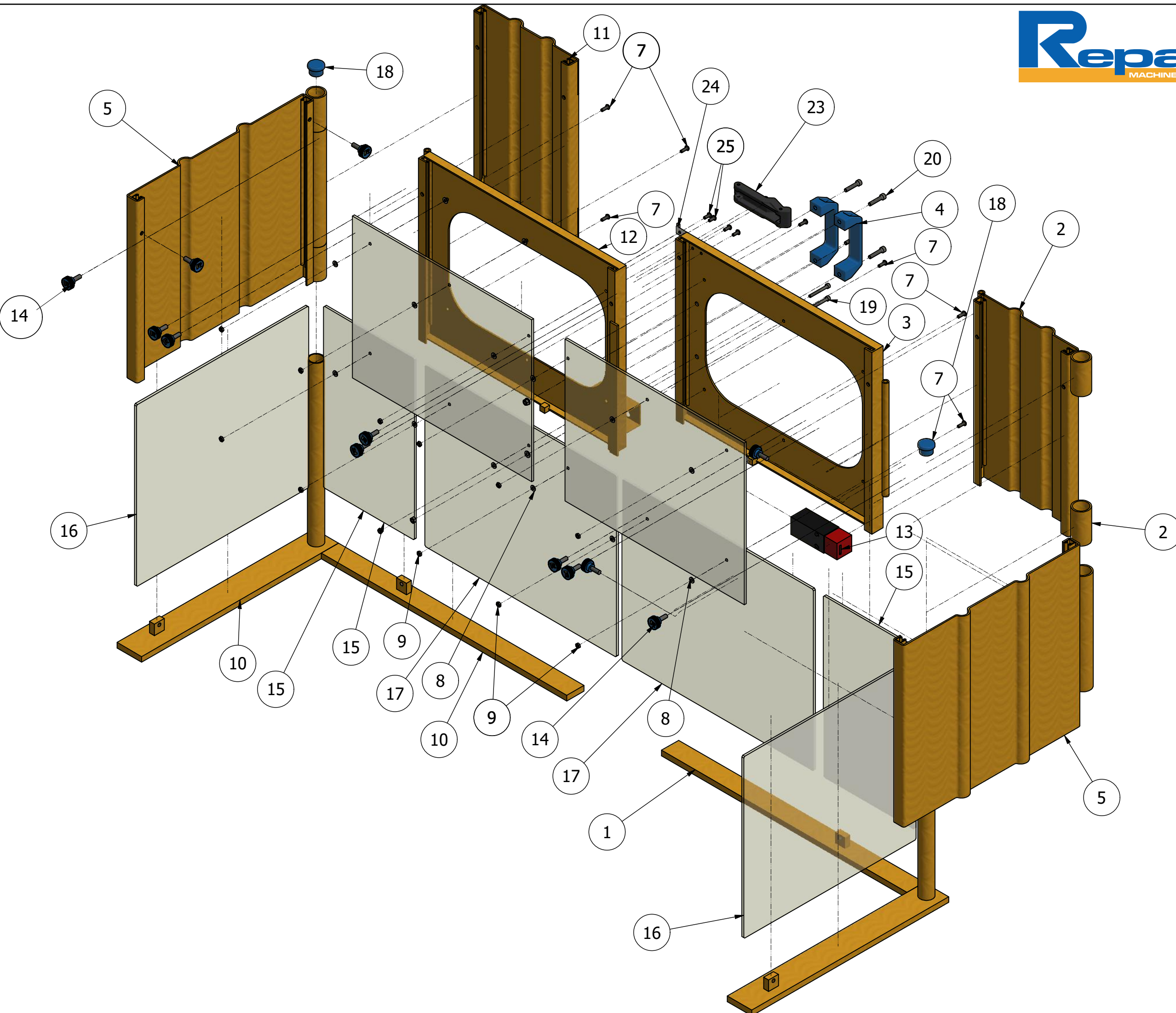

ELENCO PARTI		
ELEMENTO	QTÀ	Nome
1	1	Base sinistra
2	1	Porta esterna
3	1	Porta interna
4	2	Maniglia
5	2	Porta laterale
6	2	Policarbonato
7	12	Vite TArr M4x12
8	14	Rondella M4
9	12	Dado M4
10	1	Base Destra
11	1	Porta esterna
12	1	Porta interna
13	1	Microinterruttore
14	12	Manopola
15	2	Policarbonato
16	2	Policarbonato
17	2	Policarbonato
18	2	Tappo
19	2	Vite TE M4x35
20	4	Vite TE M5x16
21	4	Rondella M5
22	4	Dado M5
23	1	Blocco porta
24	1	Chaive blocco porta
25	4	Vite TArr M4x10